

ACHIEVING THE PEAK OF EM PIG DETECTION

By: Gavin Duncan, Online Electronics, Scotland

ABSTRACT

Pig tracking using electromagnetic transmitters is not a new concept, yet we are still uncovering ways to improve detection. As an example, the industry standard frequency for EM transmitters used in pigging applications is 22Hz however after extensive testing and by applying science, it is now becoming evident 22Hz is not the optimal frequency for pig detection. We can now look at the actual performance of different frequencies in a variety of pig tracking applications and how this affects the task at hand. We have always known that signal strength can be affected by project specific factors such as pipeline diameter, material & wall thickness, pig design, pig velocity and if the pipeline is buried or subsea. However, in addition to frequency, we now know that the specification and configuration of the transmitter itself can also have a significant impact.

This paper will detail the factors that have previously been overlooked when trying to optimise pig detection and will provide recommendations on how to positively impact the effectiveness of this task. It will evidence this using a recent example whereby we carried out comprehensive “real life” testing prior to a project to ensure that the EM transmitters were configured to ensure the highest probability and greatest efficiency of detection while meeting the battery life constraints. It will also answer the question.....Is there any logic in specifying an EM transmitter’s performance by distance through air?

THE CHALLENGE

A year ago we reviewed the published performance figures of our products and our competitors’ products and found it very inconsistent. We publish the Standard signal voltage at 1m with our reference antenna at + 20°C in air, others publish distance in air the EM signal can be detected depending on size of Tx and some didn’t disclose anything remotely useful. So we could only compare Apples with Oranges i.e. no direct comparison. Which begs the question.....Is there any logic in specifying an EM transmitter’s performance by distance through air?

So we decided to prove it isn’t. Application testing as near, as was practicable, to the actual configuration the EM Tx was to be used instead.

The purpose of the testing was to try to determine the expected performance of the 3015X on this specific project so that the customer knows what receiver signal levels they can expect at various distances from the pigs and know what maximum step size they can take along the pipeline should they need to locate a stalled pig. Taking into consideration all the various configurations of the pig and how we can optimise these to achieve peak EM detection performance.

BACKGROUND

A brief description of the equipment used for testing and their capabilities and useability.

The 3015X Electromagnetic transmitter is an ATEX certified EM transmitter used for pig tracking and location functions. The transmitter operates effectively in buried pipelines, pipelines carrying gas and in pipeline bundles. It is possible to detect the EM transmissions from a 3015X transmitter through pipeline walls in excess of 40mm thick, however performance is dependent on several factors including the type of receiver and antenna used, distance between antenna and transmitter, pig design, pig velocity pipeline diameter, pipeline material and background EM noise levels.

The EMRx is a robust, state of art, multifrequency, electromagnetic (EM) receiver used for locating lost or stalled pigs and tracking pigs fitted with any EM pig transmitters. It can also be used to confirm a pig has left or arrived at a particular location and for general monitoring of pig movements. The enhanced sensitivity permits the location of transmitters even within very heavy walled receivers/launchers, pipeline bundles or Pipe-in-Pipe. The EMRx provides three colour coded (red,

blue and white) 20x LED bar graphs which can be individually configured in the field via Bluetooth or RS485 using the EMRx Windows or Android application to display received signal at any fixed frequency between 10Hz and 30Hz.

The EMRx may be interfaced to the EMRx Windows or Android application via RS485 (Windows only) or Bluetooth which allows advanced receiver functionality including the ability to simultaneously receive and display six different frequencies between 10Hz and 30Hz, an audio output, and configuration of all receiver parameters such as the colour coded LED frequencies. The EMRx unit uses modern Digital Signal Processing (DSP) to provide enhanced functionality, signal-to-noise ratio and frequency selectivity. Full system shown in Figure 1.

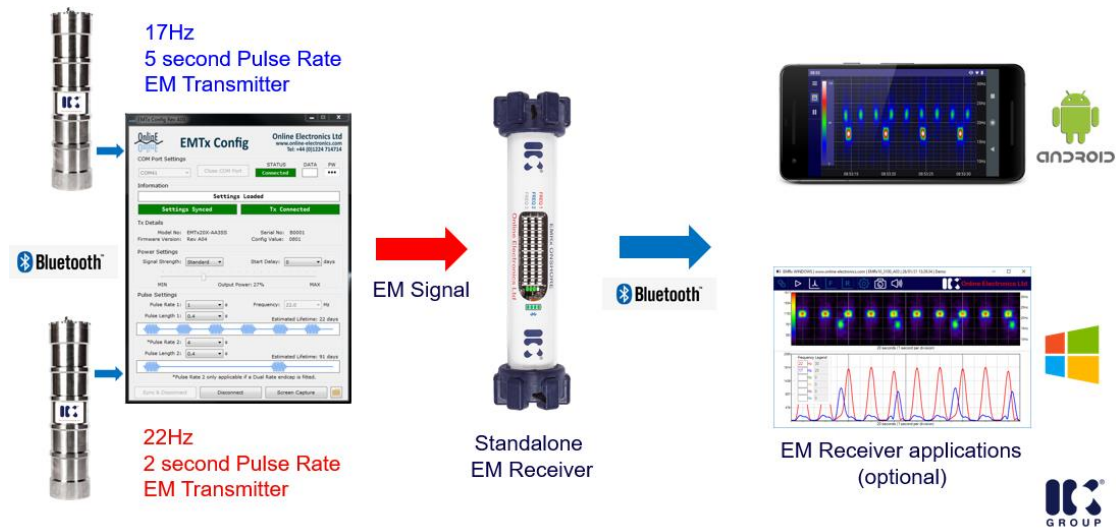

Figure 1: EMTx and EMRx wireless system

PROJECT REQUIREMENTS

The pre-commissioning project was for a subsea pipeline. The pipeline diameters and wall thicknesses are shown in table 1.

| Pipe Size | Wall Thickness |
|---------------|----------------|
| 16" (406.4mm) | 20.62mm |
| 16" (406.4mm) | 30.17mm |
| 20" (508mm) | 23.83mm |
| 20" (508mm) | 36.44mm |

Table 1: Project Pipe Dimensions

The subsea EMRx Subsea can be used either by a diver or in deeper water, up to 3000m, it can be used by an ROV usually held in a manipulator as shown in Figure 2. The EMRx Subsea can be used by monitoring the LEDs or connecting the RS485, via the ROV MUX and umbilical, to the topside so real time data can be viewed and logged.

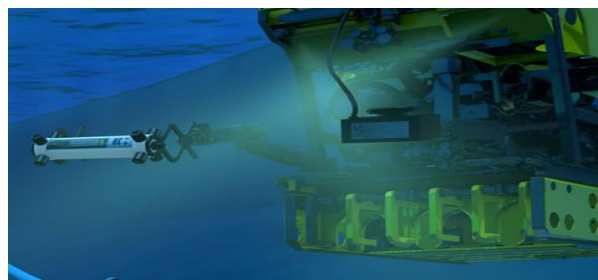

Figure 2: Subsea EMRx Subsea on ROV manipulator

TEST SET UP

The closest test pipe we had available was #11 of our test pipes with a 608mm outer diameter, 538mm internal diameter, 35mm wall thickness and 10.5m length. This is comparable (marginally thinner wall, larger diameter) to the worst-case pipe in the table above and was used for all testing.

EMRx10 was used for all testing using its Windows application connected via Bluetooth.

The EM transmitter 3015X was used throughout. This transmitter was configured for 0.4ON/3.6OFF pulsing mode. Supply current did not exceed 6mA at 17.5V assuming a cell capacity of 13000mAh at +5°C.

The test pig image shown in Figure 3 shows that the magnets are positioned around the right hand end of the transmitter and a break wire gauge plate (BWGP) around the left end of the transmitter. It was previously suspected that fitting magnets and BWGPs around an EMTx might impact EMTx performance. This will be quantified later.

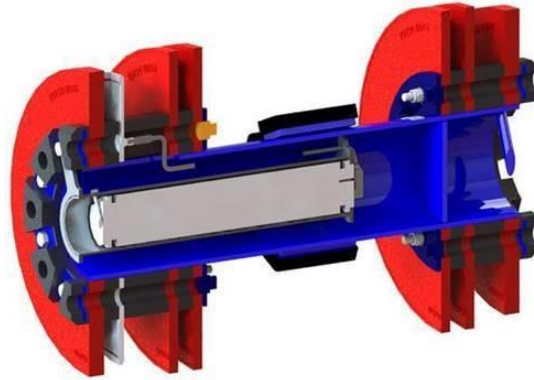

Figure 3: Model of test pig

Unless otherwise stated magnets were included in all tests in the central position. It was confirmed that all magnets were oriented with the same polarity and correct distance (250mm) from magnet edge to the front pig flange.

As with everything in our industry and at Online Electronics safety is paramount. After the risk assessment was reviewed it was decided that the pig would be loaded into the pipe on a pallet using a forklift shown in Figure 4. To allow the transmitter to be easily and accurately positioned in the middle of the pipe we used a wheeled platform, know better to most people as a “skateboard” which was ideal for the task, shown in Figure 5.



Figure 4: Test pipe with pig ready to be inserted



Figure 5: Test pig being inserted into the pipe

TESTING

Testing involved installing the 3015X inside a pig inside the test pipeline, which was not pressurised and open to air. Then using an EMRx to take readings at various distances along the pipeline and at various distances away from the pipeline surface to produce the graphs shown throughout this paper.

The test pipe was 10.5m long to ensure there were no EM end effects present. Readings were made every metre 5m either side of the centre position. At each of these positions 3 readings were taken. These were on the pipe at 0m, 0.5m from the pipe and 1m from the pipe all in air. Figure 6 shows EMRx at the centre of the pipe 1 m away.



Figure 6: EMRx positioned 1m from pipe centre

The testing scenarios were as follows:

- The EM Tx was set to 4 different frequencies: 15Hz, 17Hz, 19Hz, 22Hz.
- ROV Cradle various configurations.
- Magnets 4 positions.
- Break Wire Gauge Plate (BWGP) various configurations.

RESULTS

Reducing Frequency

The first set of results are shown in Figure 7 for all 4 frequencies at 0m (on the pipe). This shows that when the frequency was reduced from 22Hz to 19Hz, 19Hz to 17Hz & 17Hz to 15Hz respectively the received signal on the pipe increased each time. The biggest signal rise was 700 from 17Hz to 15Hz, 58%. An increase signal of 350, 55% was observed by reducing the frequency from 22Hz to 19Hz, a reduction of 3Hz rather than 2Hz for the others. Approximately the same increase of 350 was seen for 19Hz to 17Hz although this was a lower percentage increase of 41%.

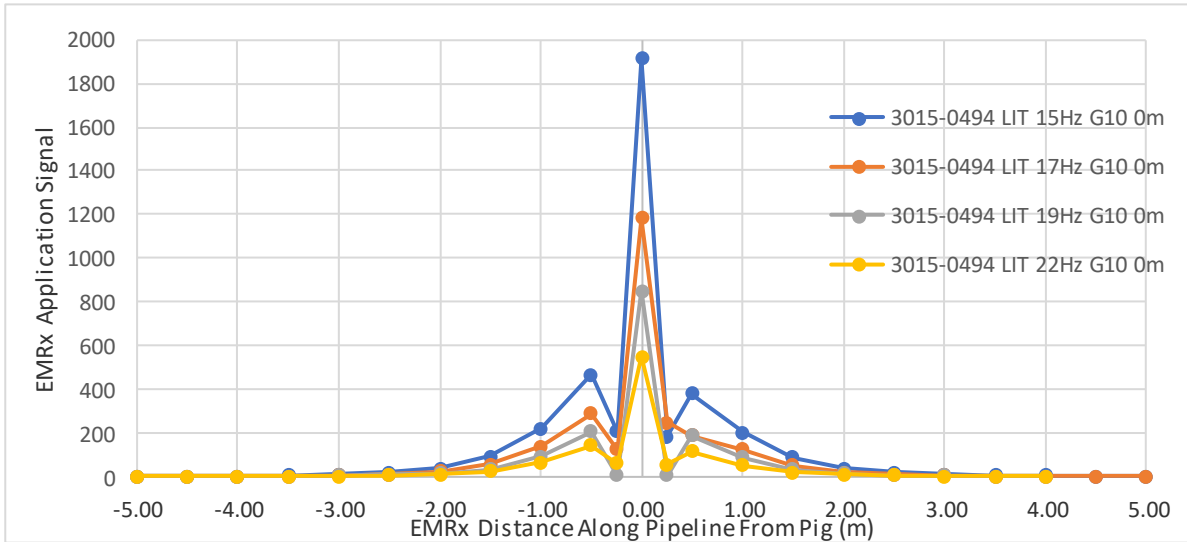

Figure 7: EM Tx @ 15Hz, 17Hz, 19Hz & 22Hz with Receiver 0m from pipe

The second set of results are shown in Figure 8 for all 4 frequencies at 0.5m distance from the pipe. Again for each frequency reduction there was an increase in received signal. As the max received signal has reduced for 15Hz from 1900 to 190 a factor of 10x then we will compare the % increase for each frequency change. At 33%, 50% & 58% signal increase for each step down in frequency.

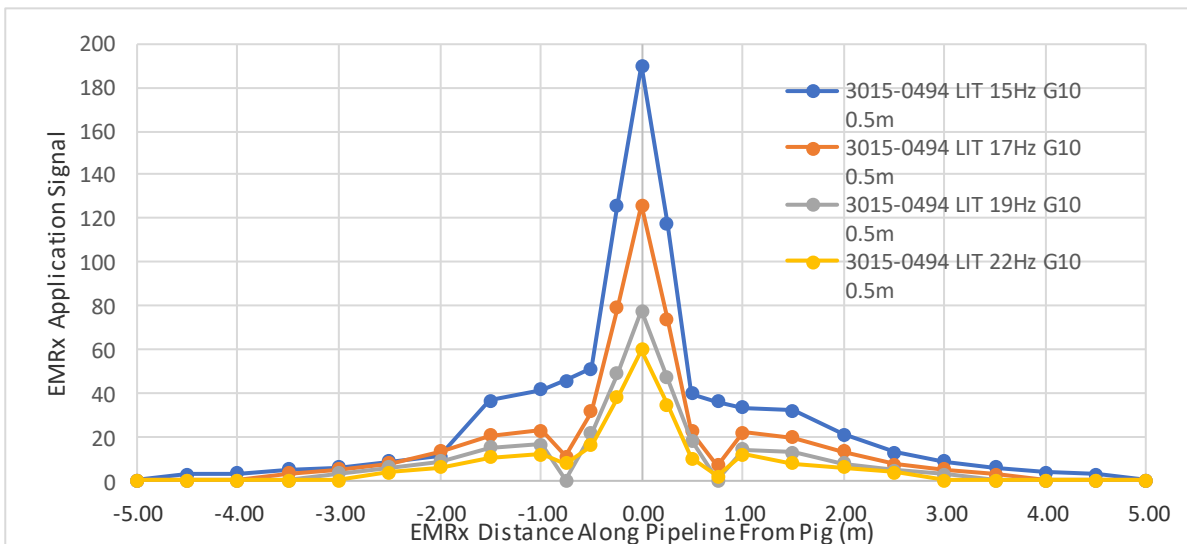

Figure 8: EM Tx @ 15Hz, 17Hz, 19Hz & 22Hz with Receiver 0.5m from pipe

The next set of results are shown in Figure 9 for all 4 frequencies at 1m distance from the pipe. A 38%, 50% & 58% signal increase in received signal for each respective step down in frequency was observed. Very similar to the previous 2 distances albeit at lower signal levels due to the increased attenuation of the signal in air.

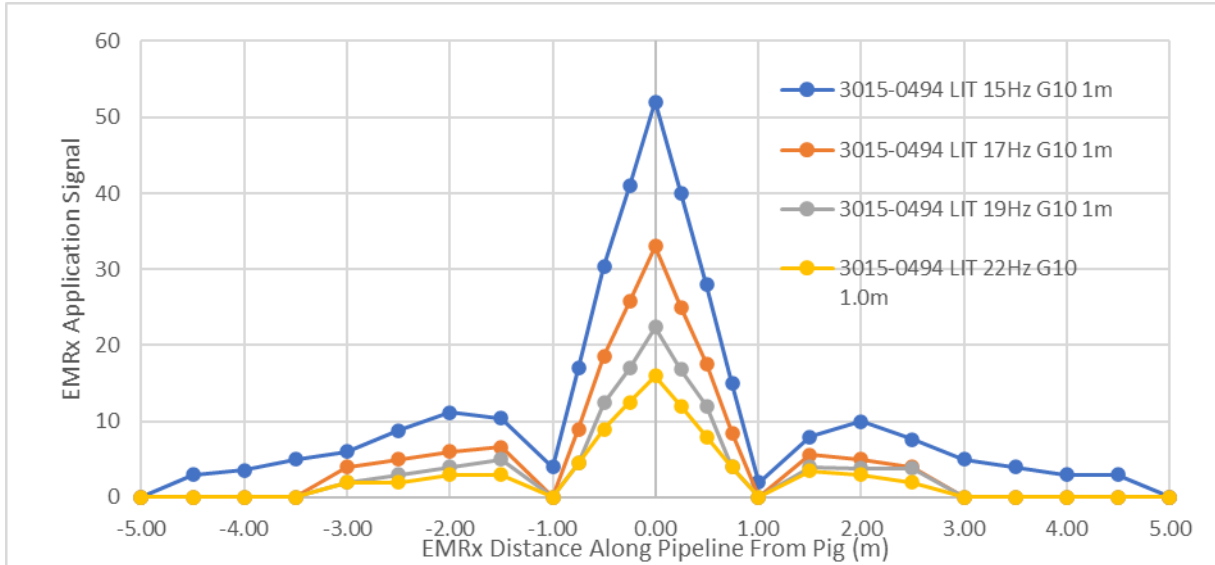

Figure 9: EM Tx @ 15Hz, 17Hz, 19Hz & 22Hz with Receiver 1m from pipe

The results show that with this configuration of pig and pipe parameters that the lower EM frequencies are easier to detect outside the pipe due to the increased received signal levels over those of the higher frequencies at all 3 distances in air from the pipe surface.

ROV Cradle Testing

If a cradle is used then it is expected to reduce achievable signals due to increased separation (approximately 65mm) between EMRx surface and pipeline surface and also the impact of additional steel between the EMRx and the pipeline. The amount of cradle steel between the EMRx and the pipeline depends on how the EMRx is mounted on the cradle. From left to right the images below shows the following test configurations:

- A. EMRx on a standard cradle. The EMRx is shown mounted on the cradle within the handle structure resulting in a steel plate between the EMRx and the pipeline.
- B. EMRx on representative plate with representative separation between pipe surface and EMRx surface.
- C. EMRx with no plate with representative separation between pipe surface and EMRx surface.



Figure 10: EMRx on various cradles options

The graph in Figure 11 below shows results from an EMRx tested in configurations A, B and C to confirm similar results.

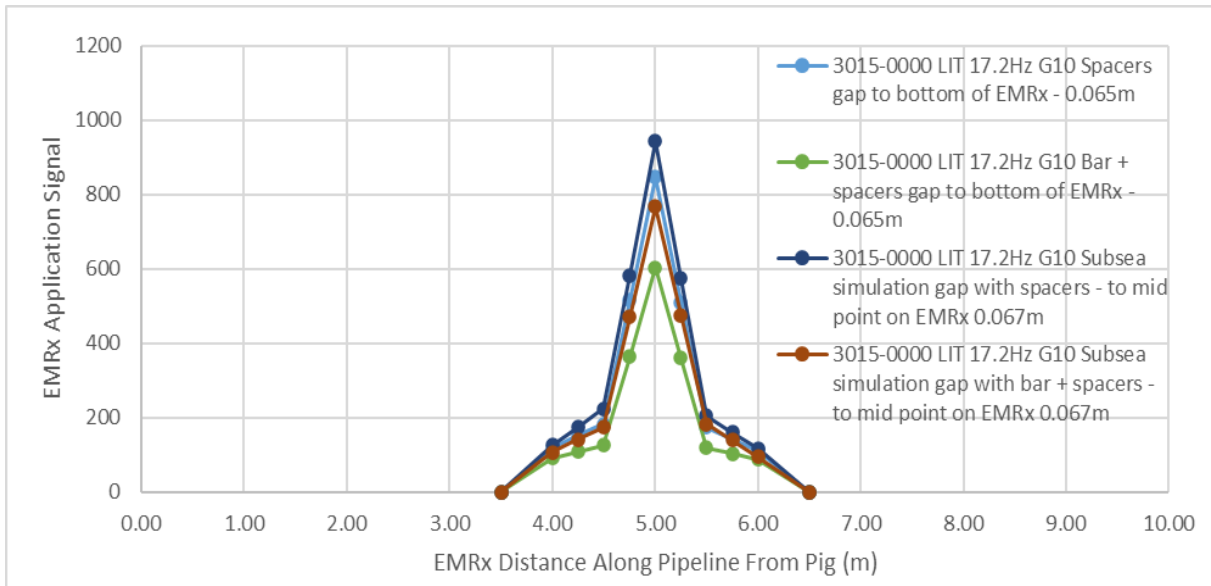

Figure 11: Received Signal with cradle configurations

It can be seen the cradle had a significant impact. The increase in separation between EMRx and pipeline from 0mm to ~65mm decreases signal by ~30%. The additional steel plate between the EMRx and the pipeline reduces signal by an additional ~30%.

Magnet Testing

Magnets were fitted to the test pig at a position 250mm from the back of the leading pig flange to the edge of the magnet packs. The pig image below in Figure 12. The transmitter position is shown in red. The magnet positions below were defined and tests were repeated to determine any advantage in repositioning the magnets.

- Magnets positioned over centre of EMTx.
- Magnets positioned as per original drawing (over edge of EMTx).
- Magnets positioned against leading flange (as far away as possible from EMTx).
- Magnets removed entirely (not shown).

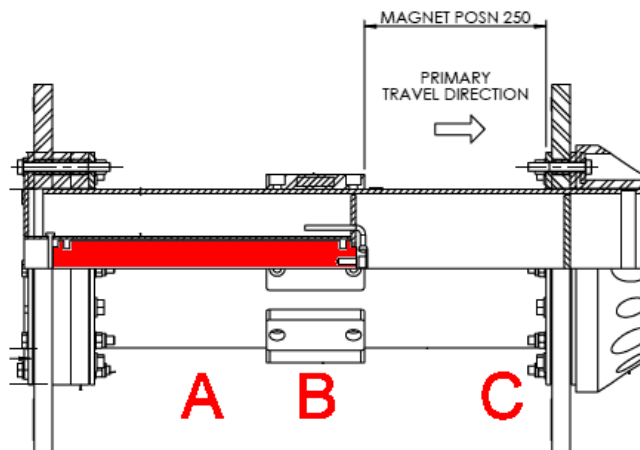

Figure 12: Magnet test positions

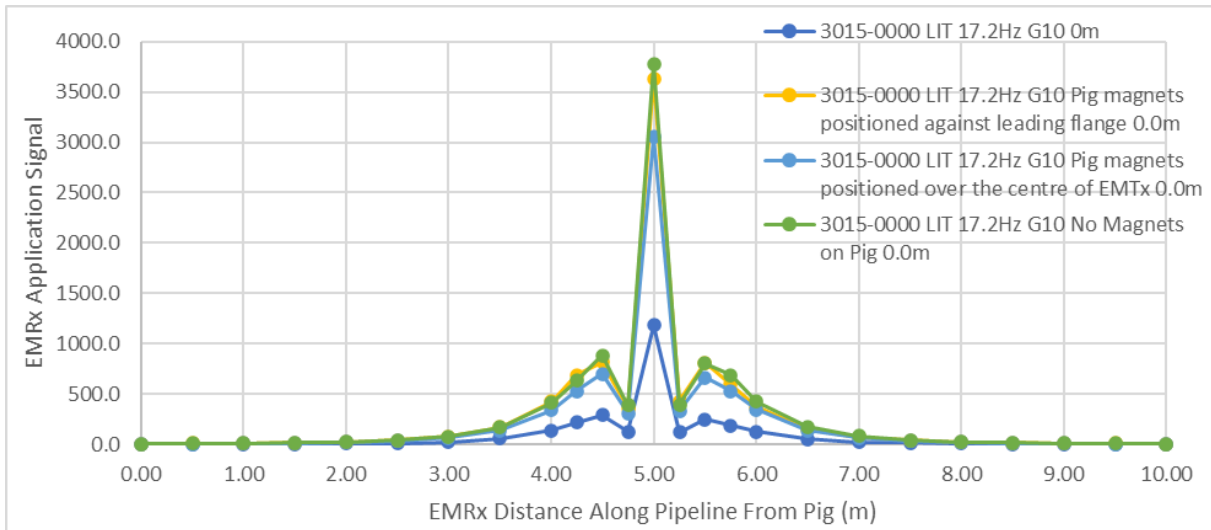

Figure 13: Received Signal with different Magnet positions

The graph shown in Figure 13 shows signals received at these positions. The original magnet position B is worst and an increase in signal of almost 300% can be achieved by repositioning magnets to A or C. This was not unexpected however the effect of the magnets positioning had far more of an effect on the received signal level than first envisaged.

BWGP Testing

When a Break Wire Gauge Plate (BWGP), shown in Figure 14, is fitted to a PIG and run through a pipeline, the system detects the first impact / defect along the pipeline. The major advantage of this system is that the operator does not need to recover the pig to visually inspect the gauge plate or run an intelligent pig - both of which are very time consuming and expensive procedures, particularly if the pig is being received subsea.



Figure 14: BWGP connected to Acoustic Pinger

The results that follow are recorded at 0m distance from the pipe surface. The results are in no way comparable to previous results because the EMTx was purposefully left protruding from the pig body to allow the BWGP to be placed over it resulting in an artificially high signal. The reason that the tests were done in this way was because none of the available BWGPs were large enough to fit over the pig body in a normal fashion. The three tests below were completed.

- A. 50% of the EMTx protruding from the pig body.
- B. As per A above with 342x147x6mm Aluminium BWGP placed over EMTx.
- C. As per A above with 375x150x8mm Aluminium BWGP placed over EMTx.

Figure 15 below shows that BWGP B should be expected to reduce the results compared to no BWGP fitted by approximately by 10% which is not particularly significant. As predicted BWGP C had more impact (approximately 25%) due to thicker material and/or smaller diameter.

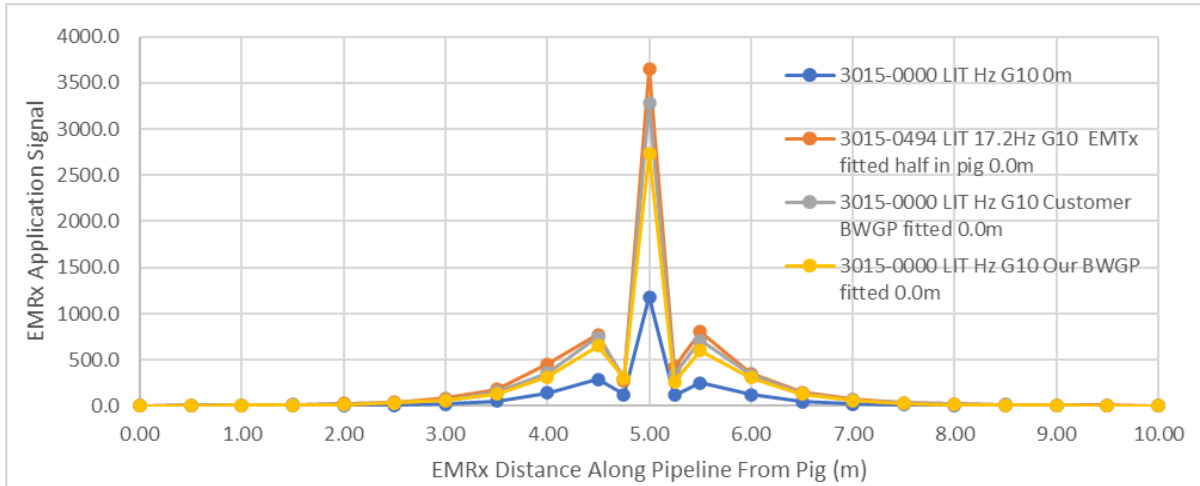

Figure 15: Received Signal with BWGP configurations

DETECTION ENVELOPE

As stated earlier the primary purpose of the testing was to try to determine the expected performance of the 3015X on this specific project so that the customer knows what signal levels they can expect at various distances from the pipelines and know what maximum step size they can take along the pipeline should they need to locate a stalled pig.

Note that Table 2 below comes with no allowance for the negative impact of a BWGP with expected reduction in signal levels of ~10% as per BWGP testing. A 10% decrease in signal has minimal impact on maximum detectable width.

Null spots are typically very narrow and relatively difficult to find however there is a chance that the receiver is placed at one. We therefore recommend a maximum step size of half the detectable width, as we think it is extremely unlikely that the receiver will be placed into both null spots on consecutive steps. From results so far we can see that if the receiver is on the pipe surface, then the null spots are typically 0.5m apart which is far less than the recommended step size.

| Separation from pipe surface (m) | Frequency (Hz) | Maximum Detectable width (m) | Maximum Step Size (m) |
|----------------------------------|----------------|------------------------------|-----------------------|
| 0.0m | 15Hz | 6.0m | 3.0m |
| | 17.2Hz | 5.0m | 2.5m |
| | 19Hz | 5.0m | 2.5m |
| | 22Hz | 4.0m | 2.0m |
| 0.5m | 15Hz | 4.5m | 2.25m |
| | 17.2Hz | 4.0m | 2.0m |
| | 19Hz | 3.5m | 1.75m |
| | 22Hz | 2.5m | 1.25m |
| 1.0m | 15Hz | 2.0m | 1.0m |
| | 17.2Hz | 1.0m | 0.5m |
| | 19Hz | 1.0m | 0.5m |
| | 22Hz | 1.0m | 0.5m |

Table 2: Detectable width at all frequencies

As can be seen from the results the maximum detectable width increases as the transmitter frequencies are reduced from the obligatory 22Hz to 19Hz, 17Hz & 15Hz. It also, as expected, decreases as the receiver is positioned further from the pipe.

DISCUSSION

Changing frequencies

As demonstrated reducing the frequency of the transmitter signal propagation provides significant improvement with the test pig and the pipe for this project. This then scientifically proves that the standard 22Hz is not always the best frequency to use to achieve optimal EM pig detection.

The lower frequencies have been proven to give a better solution for this pig & pipe combination. Mainly due to the 35mm pipe wall thickness and the combination of a stainless EMTx housing and a carbon steel pig body.

Environmental Noise

The critical parameter for any deployment involving EMRx and EMTx (3015X) is the minimum achievable level of environmental noise. So if there is a signal level of 100 but there is also environmental noise of 100 then you are not going to be able to detect your signal. Environmental noise level can be determined by deploying subsea and observing the signal received when there is no signal present. If there is almost no environmental noise when holding the EMRx Subsea in the ROV manipulator that is ideal. If the environmental noise level is approaching ~50% of the expected signal level, then we need to find a way to reduce the environmental noise. Use an ROV cradle or the diver should place the EMRx on the pipe and then step away a short distance or increase the signal, so move the EMRx closer to the pig.

If the environmental noise subsea is very low (~1) it would allow significantly wider detectable widths. It could also allow gain to be increased from G10 to G20 which would be expected to widen detectable width further.

Cradle Testing

These tests indicate that reducing the distance and removing any metal from below the EMRx can provide a significant improvement. It is therefore recommended that our optimised ROV cradles are used to allow for these improvements.

Magnets

Results show that moving the magnets have a considerable effect on the signal strength of the EMTx.

- Signal strength improved drastically at the centre point when magnets were in position A.
- The spread detection is also broader, detectable the entire length of pipe
- The difference between position B,C and D were noticeable but nothing to the extent of moving from position A.

Effect of BWGP

Suggest that placing a BWGP around an EMTx can have a significant impact (up to 1.3x) on received signal. For this project the effect is less, at x1.1, due to a thinner 6mm BWGP

EM Tx housing

It should be noted that the transmitter is mounted inside a housing within the pig. This housing was made of a stainless steel material which is known to attenuate the EM signal. Some pigs have this housing made from carbon steel, which during subsequent testing with another pig resulted in far more attenuation than stainless steel. So ideally it is better to have this housing made from stainless steel or better still be open mounted, slotted or ideally made from a composite EM transparent material. Figure 16 shows 2 common methods to mount the EMTx.

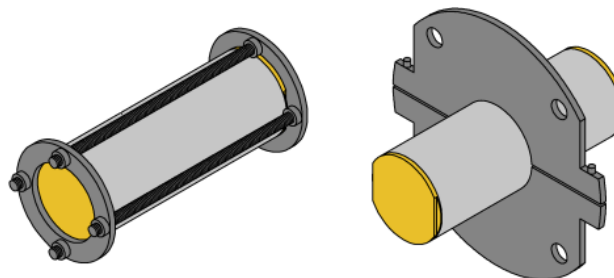

Figure 16: EMTx Mounting options

RECOMMENDATIONS

Pig and EMTx Design

Ideally everything on the pig that affects the EM signal would be made of EM transparent plastic or composite material. As we all know this is not possible for mainly functional and economic reasons. Therefore the summary of a pig to optimise the EM signal transmission is

| | |
|-------------------------|---|
| Pig body: | Stainless Steel |
| Magnets: | Positioned away from EMTx or around the centre |
| Break Wire Gauge Plate: | Minimise the thickness |
| EM transmitter housing: | If not EM transparent then slotted or clamps |
| Subsea ROV housing: | EMTx as close to pipe as possible with no steel between |

The ideal solution would be to use our option, that the transmitter can be adapted to become the pig body by fitting suitable pig discs. This effectively increases the received signal as it no longer needs to propagate through the pig body and EMTx housing in addition to the pipeline wall. This option is only suitable for smaller and simpler pigs.

Optimal Frequency?

At the beginning of this paper we stated that the perceived industry standard frequency for EM transmitters used in pigging applications is 22Hz. After our extensive testing and by applying science, it is now obvious that 22Hz is not the optimal frequency for all pig detection applications.

Due to the many different types and designs of pigs using various materials and the dimensions and the materials of the actual pipeline there are so many variables to take into consideration.

For certain operations there are additional challenges of, for example, very low flow so very long 'time' pig runs, heavy wall thickness pressure vessels / topside pipework, pigs stopped in topside pipework etc. Lowering the frequency to get better propagation of the signal allows the power level to be reduced and hence extend battery life. This maintains detectability throughout long duration runs when on continuous mode and not pulsing. Using our EMTx with Self-Regulation to ensure the signal strength is constant over the battery lifetime is ideal for these applications. Frequency can also be reduced to improve detectability for certainty of launch and receipt of the pigs. Particularly in low flow and thick walled configurations.

The single most important recommendation of this paper is to test the EM transmitter in as close to the actual application configuration "real life testing", pig & pipe, as practicably possible.

Then take time to analyse the results and review the design of the pig and specification and configuration of the EM Tx and with a few simple modifications detailed in this paper you will be far closer to achieving the peak of EM pig detection.

IS THERE ANY LOGIC IN SPECIFYING AN EM TRANSMITTER'S PERFORMANCE BY DISTANCE THROUGH AIR?

I think this paper has clearly shown that the answer to this question is absolutely not.